

KEY SYSTEM THEORY BASIC LEVELS OF CONTROL

Establishing the proper level of control for key systems is extremely important. Only after this level has been determined, can you lay out a system to suit your present and future needs. One of the main reasons many key systems disintegrate is that they were not planned at the proper level in the beginning.

The following illustrates the maximum number of levels the majority of systems will require. Succeeding images will illustrate the development of these levels.

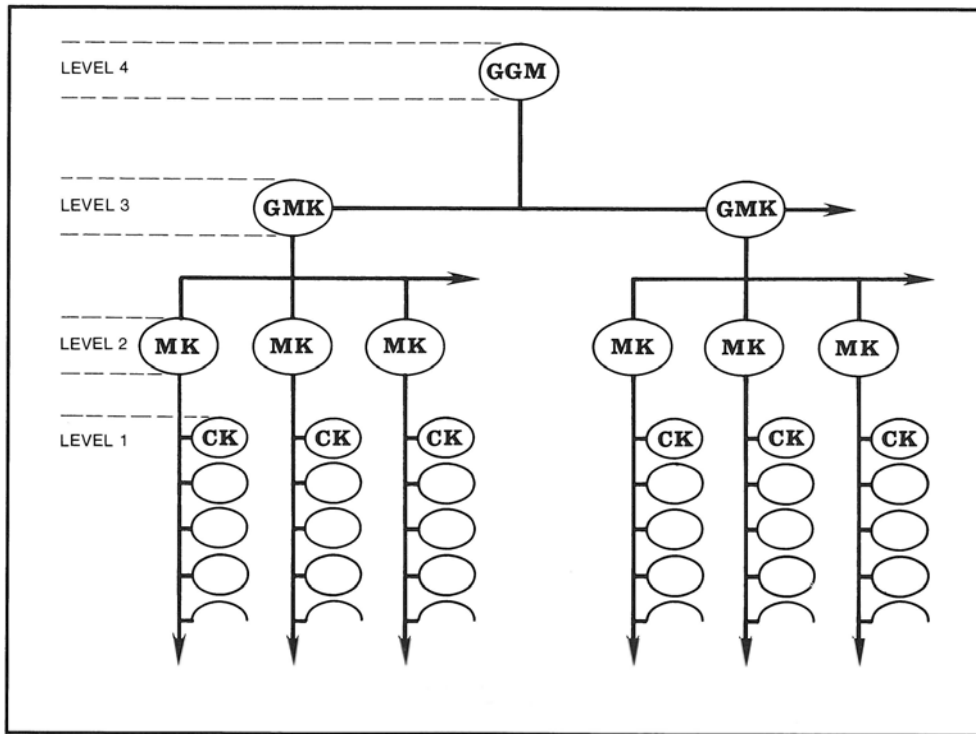

LEVEL ONE-NO MASTER KEY

Cylinders are operated by individual keys only, keyed different, or keyed alike as required. This level/type of keying offers the highest level of security.

Examples: Homes, small stores.

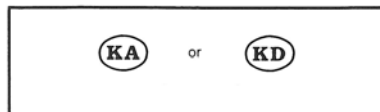

LEVEL TWO-MASTER KEY

Cylinders are operated by a change key and a master key.

Examples: Elementary schools, apartments, industrial buildings.

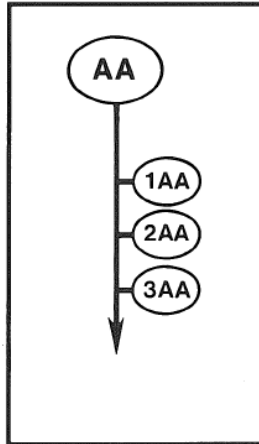

LEVEL THREE-GRAND MASTER KEY

Cylinders are operated by a change key, a master key and a grand master key.

Examples: Office buildings, large schools, hospitals.

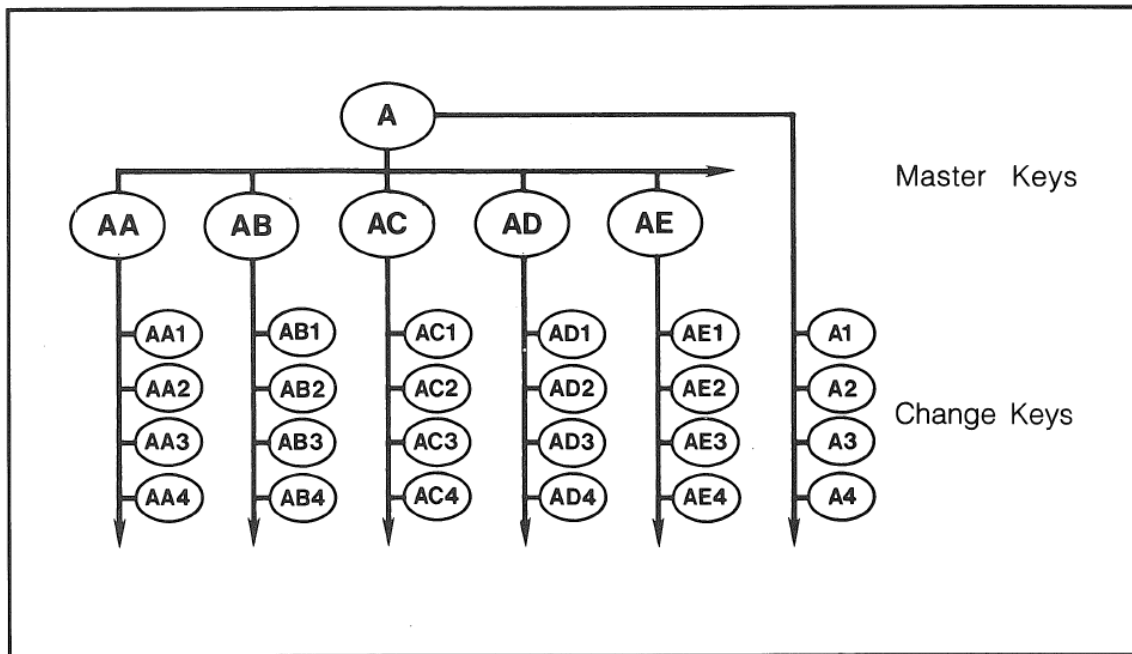

LEVEL FOUR-GREAT GRAND MASTER KEY

Cylinders are operated by a change key, a master key, a grand master key and a great grand master key. This level of keying offers the least amount of security as there needs to be many different shear lines for the different keys to unlock the lock. With this, it allows the opportunity for keys not meant for that lock to unlock it.

Examples: Very large hospitals, universities, large government complexes.

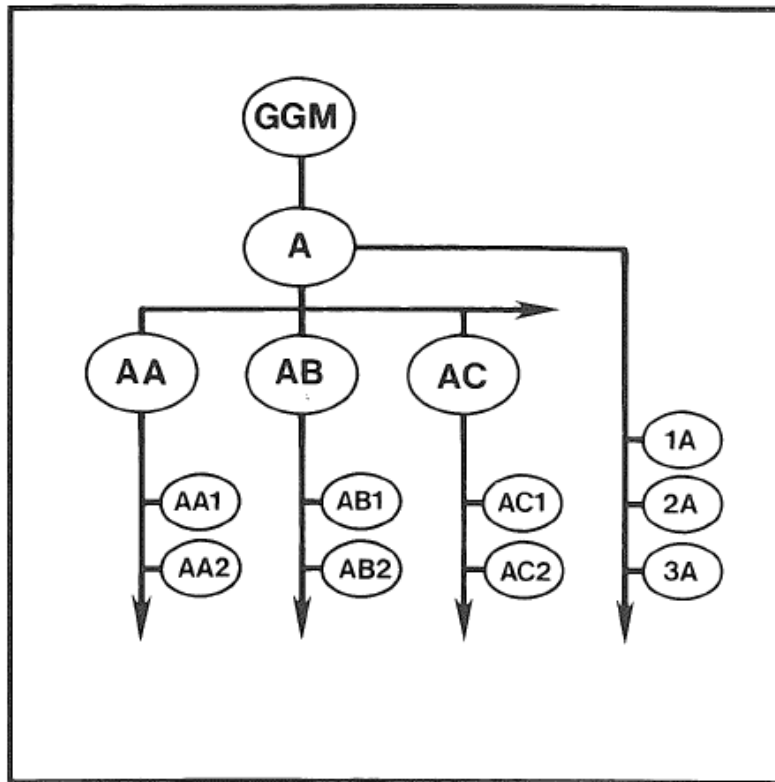

KEY AND CYLINDER CODING SYSTEM

KEYS:

Key symbols using this classification system automatically indicate the function of each key in the system without requiring any further explanation.

CYLINDERS:

When applied to a cylinder, the symbol will indicate which keys will operate that cylinder, usually without further explanation. An exception is when the cylinder is cross keying. All cylinders with the same symbol are keyed alike.

LETTERS = MASTER KEYING

NUMBERS = CHANGES

NUMBERS BEFORE LETTERS = MASTER KEYING NUMBERS AFTER

LETTERS = GRAND MASTER KEYING